

校准证书

CALIBRATION CERTIFICATE

证书编号:
Certificate No.

J201909207756-10-0003

第 1 页 共 3 页
Page of委托方
Client

HK LEE HING INDUSTRY CO., LIMITED

委托方地址
AddressSee more at: <http://www.china-gauges.com/>仪器名称
Description

Test Probe C with Cable of IEC 61032

型号/规格
Model/Type

LX-1203C

制造厂
Manufacturer

HK LEE HING INDUSTRY CO., LIMITED

出厂编号
Serial No.

JLX2019G109011

管理号
Asset No.

校准日期

2019年11月25日

Date of Calibration

Y M D

样品接收日期

2019年11月19日

Date of Receipt

Y M D

批准人:

Approved Signatory

刘文鸣 (副总监)

审核:

Inspected by

黄星顺

校准:

Calibrated by

黄星顺

证书专用章
(Stamp)

总部地址(Headquarters Add):广东省广州市黄埔大道西平云路163号

No.163.Pingyun Rd, West of HuangPu Ave.Guangzhou.Guangdong .China

承校实验室地址(Add. of the Cal. Lab): 广东省广州市黄埔大道西平云路163号

No.163.Pingyun Rd, West of HuangPu Ave.Guangzhou.Guangdong.China

联系电话(Tel.):020-38699960,66830999,400-602-0999

扫一扫验真伪

传真(Fax):020-38695185

邮政编码(Postcode):510656

网站(Website):[http:// www.grgtest.com](http://www.grgtest.com)电子邮件(E-mail):grgtest@grgtest.com



校准说明

DIRECTIONS OF CALIBRATION

证书编号: J201909207756-10-0003

第 2 页 共 3 页

Certificate No.

Page of

- 1.本实验室出具的数据可溯源至国家计量基准或社会公用计量标准。
(The data issued by GRGTest are traced to national primary standards or the public metrological standards.)
 - 2.本结果仅对本次校准样品有效。未经书面批准,不得部分复制。如有疑问请在15个工作日内反馈。(The result is only valid for the calibrated sample.The certificate shall not be reproduced except in full,without the written approval of our laboratroy .please feedback to us within 15 days if you have any question.)
 - 3.本证书编号具有唯一性,后缀若带有“-Gx”的证书为替换证书,自发出后原证书即刻作废。
(Each certificate has a unique number. The suffix of "-Gx" will be added to the number as a replacement of the old version. The original certificate will be officially invalid once the new certificate number is issued.)
 - 4.证书中如有最大允许误差、判定结果,仅供参考,其中“P”代表“合格”,“F”代表“不合格”。使用人员还应结合实际测量要求,评估校准结果测量不确定度对符合性评定的影响。(MPE & judgement result in the datasheet is only for reference , "P" represents "Pass" and "F" represents "Fail".Whereas users should evaluate the effects of MU of calibration results on conformity determination associated with actual measurement.)
 - 5.本次校准的技术依据及CNAS认可范围,超出范围的内容未被认可。详细认可范围请查看CNAS网站中注册编号为L0446的证书附件。(Reference document and accredited scope by CNAS for calibration, beyond which isn't accredited. Please see the attachment of certificate No.L0446 on CNAS website for details.)
- GRGJL.WI-CD-09-QBJZ100-2016试验指、棒、销、钩、探针校准方法 (Test finger,rod,pin,hock,probe) :
长度 (0~1000) mm; 力值 (0.001~200) N; 角度10°~120°

6. 本次校准使用的主要测量标准(Main Standards of Measurement Used in the Calibration.):

名称 / 型号 Description / Model	编 号 Serial No.	证书号/有效期 Certificate No./ Due Date	溯源机构 Traceability Institute	技术特征 Technique Character
图像处理万能工具显微镜 /JX13C	ZH0020	CYY201900266 2020-03-24	广东省计量科学 研究院	MPE: (1+L/100)μm
数显卡尺/ (0~200) mm	B17080266	J201905173576- 0007 2020-05-22	广州广电计量检 测股份有限公司	MPE:± (0.02~0.03) mm

7. 校准地点、环境条件(Place and environmental conditions of the calibration):

地点 Place	广州计量长度精密测量室	温度 Temperature	21 °C	相对湿度 Relative Humidity	60 %
-------------	-------------	-------------------	-------	---------------------------	------

8. 建议复校时间间隔: 1年,送校单位也可按实际使用情况自主决定。
Suggested calibration interval is 1 year or it can be altered depending on the actual usage of the user.



校准结果 RESULTS OF CALIBRATION

证书编号: J201909207756-10-0003

第 3 页 共 3 页

Certificate No.

Page of

1、外观以及一般性检查: 符合要求

Appearance: Pass

2、尺寸测量:

Dimension measurement:

标准要求(mm) Specifications	实际值 (mm) Measured	扩展不确定度 (mm) $U(k=2)$	结论 (P/F) Conclusion
100	99.94	0.05	--
10	10.05	0.02	--
35 ^{+0.2} -0.2	34.99	0.03	P
100 ^{+0.2} -0.2	100.06	0.05	P
2.5 ^{+0.05} 0	2.52	0.01	P

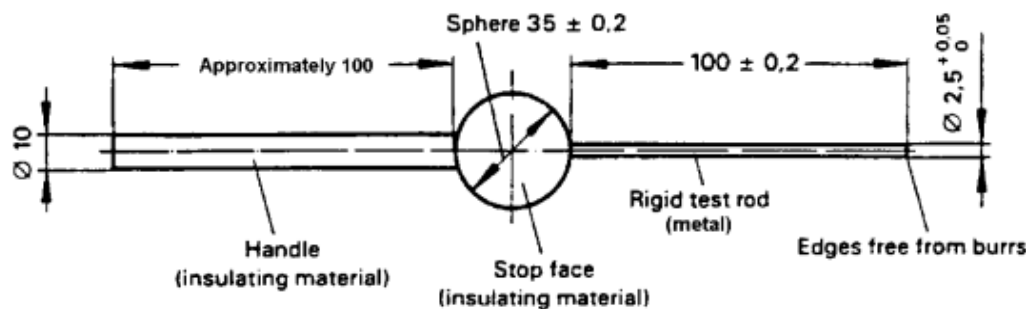

备注(Notes):

结论 (Conclusion): 按校准结果使用

1.本报告中的扩展不确定度是由标准不确定度乘以包含概率约为95%时的包含因子 k 。

The expanded uncertainty is given in the report by the standard uncertainty multiplied by the probability of about 95% when the factor k .

2.依据(Reference document)

JJF 1059.1-2012 测量不确定度评定与表示

(JJF 1059.1-2012 Evaluation and Expression of Uncertainty in Measurement)

3.技术指标来自于:

IEC61032

Technical indicators source:

(以下空白)

(The below is blank)