

BS EN 60204-31:2013



BSI Standards Publication

Safety of machinery - Electrical equipment of machines

Part 31: Particular safety and EMC requirements for sewing machines, units and systems

bsi.

...making excellence a habit.™

National foreword

This British Standard is the UK implementation of EN 60204-31:2013. It is identical to IEC 60204-31:2013. It supersedes BS EN 60204-31:1998 which is withdrawn.

The UK participation in its preparation was entrusted to Technical Committee MCE/3, Safeguarding of machinery.

A list of organizations represented on this committee can be obtained on request to its secretary.

This publication does not purport to include all the necessary provisions of a contract. Users are responsible for its correct application.

© The British Standards Institution 2013.

Published by BSI Standards Limited 2013

ISBN 978 0 580 73869 2

ICS 13.110; 61.080

Compliance with a British Standard cannot confer immunity from legal obligations.

This British Standard was published under the authority of the Standards Policy and Strategy Committee on 31 October 2013.

Amendments/corrigenda issued since publication

Date	Text affected
------	---------------

EUROPEAN STANDARD
NORME EUROPÉENNE
EUROPÄISCHE NORM

EN 60204-31

October 2013

ICS 13.110; 61.080

Supersedes EN 60204-31:1998

English version

**Safety of machines -
Electrical equipment of machines -
Part 31: Particular safety and EMC requirements for sewing machines,
units and systems
(IEC 60204-31:2013)**

Sécurité des machines -
Équipement électrique des machines -
Partie 31: Exigences particulières de
sécurité et de CEM pour machines à
coudre, unités et systèmes de couture
(CEI 60204-31:2013)

Sicherheit von Maschinen -
Elektrische Ausrüstung von Maschinen -
Teil 31: Besondere Sicherheits- und EMV-
Anforderungen an Nähmaschinen,
Näheinheiten und Nähanlagen
(IEC 60204-31:2013)

This European Standard was approved by CENELEC on 2013-05-28. CENELEC members are bound to comply with the CEN/CENELEC Internal Regulations which stipulate the conditions for giving this European Standard the status of a national standard without any alteration.

Up-to-date lists and bibliographical references concerning such national standards may be obtained on application to the CEN-CENELEC Management Centre or to any CENELEC member.

This European Standard exists in three official versions (English, French, German). A version in any other language made by translation under the responsibility of a CENELEC member into its own language and notified to the CEN-CENELEC Management Centre has the same status as the official versions.

CENELEC members are the national electrotechnical committees of Austria, Belgium, Bulgaria, Croatia, Cyprus, the Czech Republic, Denmark, Estonia, Finland, Former Yugoslav Republic of Macedonia, France, Germany, Greece, Hungary, Iceland, Ireland, Italy, Latvia, Lithuania, Luxembourg, Malta, the Netherlands, Norway, Poland, Portugal, Romania, Slovakia, Slovenia, Spain, Sweden, Switzerland, Turkey and the United Kingdom.

CENELEC

European Committee for Electrotechnical Standardization
Comité Européen de Normalisation Electrotechnique
Europäisches Komitee für Elektrotechnische Normung

CEN-CENELEC Management Centre: Avenue Marnix 17, B - 1000 Brussels

Foreword

The text of document 44/685/FDIS, future edition 4 of IEC 60204-31, prepared by IEC/TC 44 "Safety of machinery - Electrotechnical aspects" was submitted to the IEC-CENELEC parallel vote and approved by CENELEC as EN 60204-31:2013.

The following dates are fixed:

- latest date by which the document has to be implemented at national level by publication of an identical national standard or by endorsement (dop) 2014-04-01
- latest date by which the national standards conflicting with the document have to be withdrawn (dow) 2016-05-28

This document supersedes EN 60204-31:1998.

EN 60204-31:2013 includes the following significant technical changes with respect to EN 60204-31:1998:

- a) Alignment of the normative references;
- b) Alignment of titles and subtitles to the EN 60204-1;
- c) Revision of Annex AA to align this annex with the relevant European standards.

This European Standard is to be used in conjunction with EN 60204-1:2006 + A1:2009.

This part supplements or modifies the corresponding clauses in EN 60204-1 so as to convert that publication into the European standard dealing with requirements for the electrical equipment of sewing machines, units and systems.

Where a particular subclause of Part 1 is not mentioned in this part, that subclause applies as far as is reasonable. Where this part states "addition", "modification" or "replacement" the relevant text in Part 1 is adapted accordingly.

The annex which is additional to those in Part 1 is lettered AA.

Attention is drawn to the possibility that some of the elements of this document may be the subject of patent rights. CENELEC [and/or CEN] shall not be held responsible for identifying any or all such patent rights.

This document has been prepared under a mandate given to CENELEC by the European Commission and the European Free Trade Association, and supports essential requirements of EU Directive(s).

For the relationship with EU Directives see informative Annexes ZZA and ZZB, which are integral parts of this document.

Endorsement notice

The text of the International Standard IEC 60204-31:2013 was approved by CENELEC as a European Standard without any modification.

In the official version, for Bibliography, the following notes have to be added for the standards indicated:

IEC 60335-2-28 NOTE Harmonised as EN 60335-2-28.

IEC 61000-6-2:2005 NOTE Harmonised as EN 61000-6-2:2005 (not modified).

<http://www.china-gauges.com/>

Annex ZA (normative)

Normative references to international publications with their corresponding European publications

The following documents, in whole or in part, are normatively referenced in this document and are indispensable for its application. For dated references, only the edition cited applies. For undated references, the latest edition of the referenced document (including any amendments) applies.

NOTE When an international publication has been modified by common modifications, indicated by (mod), the relevant EN/HD applies.

Addition to Annex ZA of EN 60204-1:2006:

<u>Publication</u>	<u>Year</u>	<u>Title</u>	<u>EN/HD</u>	<u>Year</u>
IEC 60204-1 (mod) + A1	2005 2008	Safety of machinery - Electrical equipment of machines - Part 1: General requirements	EN 60204-1 + corr. February + A1	2006 2010 2009
IEC 60364-4-41	-	Low-voltage electrical installations - Part 4-41: Protection for safety - Protection against electric shock	HD 60364-4-41	-
IEC 60664-1	2007	Insulation coordination for equipment within low-voltage systems - Part 1: Principles, requirements and tests	EN 60664-1	2007
IEC 60721-3-3	-	Classification of environmental conditions - Part 3: Classification of groups of environmental parameters and their severities - Section 3: Stationary use at weatherprotected locations	EN 60721-3-3	-
IEC 60947-1 + A1	2007 2010	Low-voltage switchgear and controlgear - Part 1: General rules	EN 60947-1 + A1	2007 2011
IEC 61000-3-2	-	Electromagnetic compatibility (EMC) - Part 3-2: Limits - Limits for harmonic current emissions (equipment input current ≤ 16 A per phase)	EN 61000-3-2	-
IEC 61000-3-3	-	Electromagnetic compatibility (EMC) - Part 3-3: Limits - Limitation of voltage changes, voltage fluctuations and flicker in public low-voltage supply systems, for equipment with rated current ≤ 16 A per phase and not subject to conditional connection	EN 61000-3-3	-
IEC 61000-4-2	-	Electromagnetic compatibility (EMC) - Part 4-2: Testing and measurement techniques - Electrostatic discharge immunity test	EN 61000-4-2	-
IEC 61000-4-3	-	Electromagnetic compatibility (EMC) - Part 4-3: Testing and measurement techniques - Radiated, radio-frequency, electromagnetic field immunity test	EN 61000-4-3	-
IEC 61000-4-4	-	Electromagnetic compatibility (EMC) - Part 4-4: Testing and measurement techniques - Electrical fast transient/burst immunity test	EN 61000-4-4	-

<u>Publication</u>	<u>Year</u>	<u>Title</u>	<u>EN/HD</u>	<u>Year</u>
IEC 61000-4-5 + corr. October	2005 2009	Electromagnetic compatibility (EMC) - Part 4-5: Testing and measurement techniques - Surge immunity test	EN 61000-4-5	2006
IEC 61000-4-6	-	Electromagnetic compatibility (EMC) - Part 4-6: Testing and measurement techniques - Immunity to conducted disturbances, induced by radio-frequency fields	EN 61000-4-6	-
IEC 61000-4-11	-	Electromagnetic compatibility (EMC) - Part 4-11: Testing and measurement techniques - Voltage dips, short interruptions and voltage variations - Immunity tests	EN 61000-4-11	-
IEC 61058-1	-	Switches for appliances - Part 1: General requirements	EN 61058-1	-
IEC 61558-1	-	Safety of power transformers, power supplies, reactors and similar products - Part 1: General requirements and tests	EN 61558-1	-
CISPR 11 (mod) + A1	2009 2010	Industrial, scientific and medical equipment - Radio-frequency disturbance characteristics - Limits and methods of measurement	EN 55011 + A1	2009 2010
ENV 50204	-	Radiated electromagnetic field from digital radio telephones - Immunity test	-	-

Annex ZZA (informative)

Coverage of Essential Requirements of EU Directive (2006/42/EC)

This European Standard has been prepared under a mandate given to CENELEC by the European Commission and the European Free Trade Association and within its scope the standard covers only the following essential requirement out of those given in annex I of the EC Directive 2006/42/EC:

– 1.5.1

Compliance with this standard provides one means of conformity with the specified essential requirements of the Directive concerned.

WARNING: Other requirements and other EU Directives may be applicable to the products falling within the scope of this standard.

Annex ZZB (informative)

Coverage of Essential Requirements of EU Directive (2004/108/EC)

This European Standard has been prepared under a mandate given to CENELEC by the European Commission and the European Free Trade Association and within its scope the standard covers all relevant essential requirements as given in Annex I of the EC Directive 2004/108/EC.

Compliance with this standard provides one means of conformity with the specified essential requirements of the Directive concerned.

WARNING: Other requirements and other EC Directives may be applicable to the products falling within the scope of this standard.

CONTENTS

1	Scope	5
2	Normative references	5
3	Terms and definitions	6
4	General requirements	7
5	Incoming supply conductor terminations and devices for disconnecting and switching off	7
6	Protection against electric shock	8
7	Protection of equipment	8
8	Equipotential bonding	9
9	Control circuits and control functions	9
10	Operator interface and panel mounted control devices	10
11	Controlgear: location, mounting and enclosures	11
12	Conductors and cables	12
13	Wiring practices	12
14	Electric motors and associated equipment	12
15	Accessories and lighting	13
16	Marking, warning signs and reference designations	13
17	Technical documentation	13
18	Verification	14
	Annex AA (normative) Electromagnetic compatibility requirements	15
	Bibliography	22
	Figure AA.1 – Ports	15
	Figure AA.2 – Standard sewing unit for EMC tests	17
	Table AA.1 – Emission – Radiated (enclosure) and conducted (AC mains)	18
	Table AA.2 – Immunity – Enclosure port	19
	Table AA.3 – Immunity – Ports for signal lines and data buses	20
	Table AA.4 – Immunity – AC input and AC output power ports	21

SAFETY OF MACHINERY – ELECTRICAL EQUIPMENT OF MACHINES –

Part 31: Particular safety and EMC requirements for sewing machines, units and systems

1 Scope

This clause of Part 1 is replaced by:

This part of IEC 60204 applies to the application of electrical and electronic equipment to sewing machines, units and systems, designed specifically for professional use in the sewing industry.

NOTE The requirements for sewing machines for household and similar use can be found in IEC 60335-2-28.

The equipment covered by this part commences at the point of connection of the supply to the electrical equipment of the machine (see 5.1). This part is applicable to the electrical equipment or parts of the electrical equipment which operate with nominal supply voltages not exceeding 1 000 V for alternating current and not exceeding 1 500 V for direct current, and with nominal frequencies not exceeding 200 Hz.

It does not cover all the requirements (e.g. guarding, interlocking, control) that are necessary to safeguard persons from hazards other than electrical hazards and which are specified in other standards.

This part applies to sewing units and systems which are installed in dry and well-kept clean locations and which process dry sewing material, as in the clothing industry. Where sewing units and systems are used in other than dry and well-kept clean locations, more stringent measures can be necessary, which need to be agreed between manufacturer and customer.

The noise emission of electrical and electronic equipment for sewing machines is not considered to be a relevant hazard. Therefore this standard does not contain any specific requirements on noise.

2 Normative references

This clause of Part 1 is applicable except as follows:

Additional references:

IEC 60204-1:2005, *Safety of machinery – Electrical equipment of machines – Part 1: General requirements*
Amendment 1:2008

IEC 60364-4-41, *Low-voltage electrical installations – Part 4-41: Protection for safety – Protection against electric shock*

IEC 60664-1:2007, *Insulation coordination for equipment within low-voltage systems – Part 1: Principles, requirements and tests*

IEC 60721-3-3, *Classification of environmental conditions – Part 3: Classification of groups of environmental parameters and their severities – Section 3: Stationary use at weatherprotected locations*

IEC 60947-1:2007, *Low-voltage switchgear and controlgear – Part 1: General rules*
Amendment 1:2010

IEC 61000-3-2, *Electromagnetic compatibility (EMC) – Part 3-2: Limits – Limits for harmonic current emissions (equipment input current ≤ 16 A per phase)*

IEC 61000-3-3, *Electromagnetic compatibility (EMC) – Part 3-3: Limits – Limitation of voltage changes, voltage fluctuations and flicker in public low-voltage supply systems, for equipment with rated current ≤ 16 A per phase and not subject to conditional connection*

IEC 61000-4-2, *Electromagnetic compatibility (EMC) – Part 4-2: Testing and measurement techniques – Electrostatic discharge immunity test*

IEC 61000-4-3, *Electromagnetic compatibility (EMC) – Part 4-3: Testing and measurement techniques – Radiated, radio-frequency, electromagnetic field immunity test*

IEC 61000-4-4, *Electromagnetic compatibility (EMC) – Part 4-4: Testing and measurement techniques – Electrical fast transient/burst immunity test*

IEC 61000-4-5:2005, *Electromagnetic compatibility (EMC) – Part 4-5: Testing and measurement techniques – Surge immunity test*

IEC 61000-4-6, *Electromagnetic compatibility (EMC) – Part 4-6: Testing and measurement techniques – Immunity to conducted disturbances, induced by radio-frequency fields*

IEC 61000-4-11, *Electromagnetic compatibility (EMC) – Part 4-11: Testing and measurement techniques – Voltage dips, short interruptions and voltage variations immunity tests*

IEC 61058-1, *Switches for appliances – Part 1: General requirements*

IEC 61558-1, *Safety of power transformers, power supplies, reactors and similar products – Part 1: General requirements and tests*

CISPR 11:2009, *Industrial, scientific and medical equipment – Radio-frequency disturbance characteristics – Limits and methods of measurement*
Amendment 1:2010

ENV 50204, *Radiated electromagnetic field from digital radio telephones – Immunity test*

3 Terms and definitions

This clause of Part 1 is applicable except as follows:

Additional definitions:

3.101

sewing machine

machine designed to produce one or more stitch types with one or more sewing threads

Note 1 to entry: Previously, the term “sewing machine head” was used instead of “sewing machine”.

Note 2 to entry: Stitch types are defined in ISO 4915.

Note 3 to entry: Seam types are defined in ISO 4916.

Note 4 to entry: In producing a seam, the machine can perform one or more sewing functions.

**3.102
sewing machine stand**

item, for example designed as a table, on which the sewing machine is arranged to enable optimum operation

**3.103
sewing machine drive**

equipment that drives a sewing machine, such as an electric motor, which is speed-controlled by electrical and/or mechanical means with or without a positioning device and with or without control of machine functions

**3.104
sewing unit**

equipment consisting of at least a sewing machine, a sewing machine stand and a sewing machine drive

Note 1 to entry: One or several devices incorporated in and/or attached to the sewing machine or sewing unit, for example for sewing, cutting, feeding, etc. the sewing material, as well as the sewing machine itself, are controlled by the operator or automatically.

**3.105
sewing system**

equipment consisting of at least two sewing units or parts of them, which are functionally interlinked

4 General requirements

This clause of Part 1 is applicable except as follows:

4.4.2 Electromagnetic compatibility (EMC)

Replacement:

Replace this subclause with Annex AA.

4.4.4 Humidity

Modification:

Instead of the first paragraph, the following applies:

The electrical equipment shall be capable of operating in the intended manner in the humidity conditions covered by class 3K3 as specified in IEC 60721-3-3.

5 Incoming supply conductor terminations and devices for disconnecting and switching off

This clause of Part 1 is applicable except as follows:

5.1 Incoming supply conductor terminations

Modification:

Add after the first sentence of the first paragraph:

Each sewing unit shall have only one incoming supply connection.

Each sewing system consisting of at least two sewing units that are not interlinked by means of control systems may have its own incoming supply connection for each sewing unit; however, if a failure of one sewing unit can cause a hazard, the sewing system shall have only one incoming supply connection.

5.3 Supply disconnecting (isolating) device

5.3.1 General

Addition:

When sewing units are interlinked by means of control systems to form a sewing system, only one supply disconnecting device shall be provided.

5.3.2 Type

Addition to item d):

On sewing units and systems which are started and stopped by actuating a hold-to-run control device (e.g. pedal), an isolating switch according to IEC 60947-3 for utilization categories AC-3 or DC-3, or a incorporated switch according to IEC 61058-1, shall be used.

5.3.4 Operating means

Addition:

For seated positions the operating handle of the ON/OFF switch shall be mounted between 0,5 m and 1,5 m above the servicing level.

6 Protection against electric shock

This clause of Part 1 is applicable except as follows:

6.1 General

Addition:

This can also be achieved by the application of SELV according to IEC 60364-4-41.

7 Protection of equipment

This clause of Part 1 is applicable except as follows:

7.5 Protection against supply interruption or voltage reduction and subsequent restoration

Addition:

On sewing units and systems, which are started by actuating a hold-to-run control device (such as a pedal), and stopped by releasing it, the provision of a device for avoiding an unintentional restart after a supply interruption or voltage reduction and subsequent restoration is not necessary.

8 Equipotential bonding

This clause of Part 1 is applicable except as follows:

8.2.5 Parts that need not be connected to the protective bonding circuit

Addition:

It is not necessary to connect sewing machine stands or their accessible conducting parts when:

- they do not carry electrical equipment; or
- they carry electrical equipment operated as SELV and/or PELV only (see IEC 60364-4-41).

9 Control circuits and control functions

This clause of Part 1 is applicable except as follows:

9.1.1 Control circuit supply

Replacement:

Control circuits of sewing units and systems shall meet requirements for PELV (see 6.4) or SELV (see IEC 60364-4-41). The transformers supplying these circuits shall meet the requirements of IEC 61558-1.

9.2.5.2 Start

Addition:

The requirements of 9.2.5.2 do not apply to:

- sewing units and systems, which are started by actuating a hold-to-run control device (such as a pedal).

9.2.5.3 Stop

Addition:

The stop function required for sewing units and systems is met by a hold-to-run control devices (such as a pedal). On sewing units and systems for automatic bar tacking, sewing of buttonholes, fastening of buttons, etc., which have a short sewing cycle, the required function is met by an ON/OFF switch according to IEC 60947-3 or IEC 61058-1.

9.4 Control functions in the event of failure

9.4.1 General requirements

Addition:

NOTE On sewing units and systems on which the hazardous movement of parts is protected by fixed guards, interlocking of the guard with the electrical circuit is not necessary.

9.4.2.2 Provisions of partial or complete redundancy

Addition:

NOTE On sewing units and systems on which the hazardous movement of parts is limited to parts of the sewing machine itself, for example stitch forming elements, feed, etc., use of redundancy is not necessary.

9.4.2.3 Provision of diversity

Addition:

NOTE On sewing units and systems on which the hazardous movement of parts is limited to parts of the sewing machine itself, for example stitch forming elements, feed, etc., use of diversity is not necessary.

9.4.3.1 Earth faults

Addition:

On sewing units and systems, a particularly safe installation of those conductors that in the case of an earth fault could cause unintended starting, or hazardous movement of a machine, or could prevent its stopping, may be used instead of connecting the control circuits to the protective bonding circuit or providing an insulation monitoring device.

A particularly safe installation can be achieved, for example, by:

- enclosure of insulated conductors in ducts of insulating material;
- use of double insulation techniques; or
- encapsulation of components and devices.

10 Operator interface and machine mounted control devices

This clause of Part 1 is applicable except as follows:

10.1.2 Location and mounting

Modification:

Replace the first dashed indent of the second paragraph by the following:

- those used for normal operation are not less than 0,5 m above the servicing level and are within easy reach from the normal working position of the operator (but see also 5.3.4 of this part);
- those used for adjustment and maintenance are not less than 0,3 m above the servicing level and so installed that they cannot be actuated during normal operation for example by position, locking, etc.

10.1.3 Protection

Replacement:

Where mounted as intended, operator interface and machine mounted control devices shall withstand the stresses of the expected use and shall have a minimum degree of protection of at least IP40 (see IEC 60529). IP40 is considered to be sufficient when sewing units and sewing systems are operated in an environment in which the effects of aggressive fluids, vapours and contamination by coarse dust and chips are not to be expected.

10.2 Push-buttons

10.2.1 Colours

Modification:

Instead of the first paragraph, the following applies:

As far as is practicable, push-button actuators shall be colour-coded in accordance with Table 2; limitations of the practicability are sizes of actuators, built-in casing and design of actuators.

10.3 Indicator lights and displays

10.3.2 Colours

Modification:

Instead of the first sentence, the following applies:

As far as is practicable, indicator light lenses shall be colour-coded, with respect to the condition (status) of the machine in accordance with Table 4; limitations of the practicability are sizes of actuators, built-in casing and design of actuators.

10.4 Illuminated push-buttons

Modification:

Instead of the first sentence, the following applies:

As far as is practicable, illuminated push-buttons shall be colour-coded in accordance with Tables 2 and 4; limitations of the practicability are sizes of actuators, built-in casing and design of actuators.

10.7.4 Local operation of the supply disconnecting device to effect emergency stop

Addition:

On automatically controlled sewing units and systems for which emergency stop devices according to 10.7.2 are considered to be unnecessary, the supply disconnecting device shall fulfil the function of the emergency stop device.

On sewing units and systems which are started by actuating a hold-to-run control device (such as a pedal), an emergency stop device is not required. Moreover, an emergency stop device is not necessary on automatically controlled sewing units and systems for automatic bar tacking, sewing of buttonholes, fastening of buttons, etc., which have only a short automatic sewing process.

These sewing units and systems may be equipped with a device according to IEC 60947-3 or IEC 61058-1 for switching ON and OFF.

11 Controlgear: location, mounting and enclosures

This clause of Part 1 is applicable except as follows:

11.2 Location and mounting

11.2.1 Accessibility and maintenance

Modification:

Instead of the second paragraph, the following applies:

Where access is required for regular maintenance or adjustment, the relevant devices shall be arranged between 0,3 m and 2,0 m above the servicing level.

11.2.2 Physical separation or grouping

Addition:

In enclosures according to 6.2.1, the distances between the protective enclosure and live parts shall be not less than the clearance and creepage distances given in Table 13, Case A and Table 15 of IEC 60947-1:2007, Amendment 1:2010, pollution degree 2 shall apply.

For printed circuit assemblies and all other electrical equipment and devices (such as switches, motors), IEC 60664-1:2007, Table F.4, pollution degree 2 shall apply.

11.3 Degrees of protection

Replacement:

The minimum degree of protection shall be IP40 for enclosures of switching devices of sewing units and systems. **Exception:** if all the circuits used in and with the devices meet the requirements of 6.1 of this part of IEC 60204, IP20 is permitted as the minimum degree of protection.

12 Conductors and cables

This clause of Part 1 is applicable.

13 Wiring practices

This clause of Part 1 is applicable except as follows:

13.2.4 Identification by colour

Addition:

Conductors used for functional earthing shall be identified by the colour GREY.

Common conductors, for example for eliminating static charges, shall be identified by the colour GREY.

13.5.8 Connection boxes and other boxes

Modification:

Instead of the second sentence of the first paragraph, the following applies:

IP40 (see IEC 60529) shall be the minimum degree of protection for connection and through boxes of sewing units and systems. **Exception:** if all the circuits used in and with the devices meet the requirements of 6.1 of this part of IEC 60204, IP20 is permitted as the minimum degree of protection.

14 Electric motors and associated equipment

This clause of Part 1 is applicable except as follows:

14.1 General requirements

Addition:

Voltage transformation for the purpose of feeding external consumers (loads) by tapping the stator winding of motors is not permitted.

14.2 Motor enclosures

Addition:

The minimum degree of protection of the sewing machine drive (including the control device possibly attached to it) shall be IP40.

14.3 Motor dimensions

Addition:

The dimensions of sewing machine drives need not correspond to IEC 60072-1 and IEC 60072-2.

15 Accessories and lighting

This clause of Part 1 is applicable except as follows:

15.2 Local lighting of the machine and equipment

15.2.1 General

Addition:

For local lighting (sewing lamps) of sewing units and systems up to a rated voltage of 50 V a.c., the ON/OFF switch may be incorporated in the flexible connecting cords.

15.2.2 Supply

Addition:

Low-voltage sewing lamps shall be supplied either by built-in transformers or by external extra-low voltage transformers according to IEC 61558-1.

Circuits for local lighting (sewing lamps) intended for use, for example threading, replacing sewing implements, maintenance work, shall be connected to the incoming supply side of the device for switching ON and OFF the sewing unit or system.

16 Marking, warning signs and reference designations

This clause of Part 1 is applicable.

17 Technical documentation

This clause of Part 1 is applicable except as follows:

17.7 Operating manual

Addition:

<http://www.china-gauges.com/>

The instructions shall draw attention to the need always to switch off the sewing unit or system, for example by actuating the ON/OFF switch or by disconnecting the plug from the incoming supply, when:

- sewing implements (such as sewing machine needle, presser foot, bobbin or needle plate) have to be replaced;
- threading a needle, looper, spreader, etc. is required;
- the workplace is left unattended;
- maintenance work has to be performed.

18 Verification

This clause of Part 1 is applicable except as follows:

18.1 General

Addition:

The tests of 18.2, 18.3, 18.4 and 18.7 are routine tests.

The tests of 18.5 and 18.6 are type tests.

18.3 Insulation resistance tests

Addition:

Control and signal circuits containing electronic devices shall be connected to the protective conductor while the other circuits are tested. After disconnecting the protective conductor connection mentioned above, the insulation resistance to earth shall be measured in a second test with at least 100 V d.c. The test voltage shall not be applied suddenly in order to avoid any damage to the electronic circuit.

18.4 Voltage tests

Addition:

Such disconnected components include rectifiers, capacitors, electronic devices and motors up to a rated power of 1 kW.

Motors shall be tested according to IEC 60034-1. Electronic circuits of below 50 V rated voltage shall not be subjected to a voltage test.

If the electrical equipment of the machine contains surge protection devices which are likely to operate during the test, it is permitted to either:

- disconnect these devices, or
- reduce the test voltage to a value lower than the voltage protection level of the surge protection devices, but not lower than the peak value of the upper limit of the supply (phase to neutral) voltage.

Annexes

The annexes of Part 1 are applicable except as follows:

Addition:

Annex AA (normative)

Electromagnetic compatibility requirements

AA.1 General

The objective of this annex is to define limits for sewing units, sewing systems and their equipment, e.g. sewing machine drives, controls, etc. in relation to electromagnetic emissions which may cause interference in other equipment, and in relation to continuous and transient, conducted and radiated disturbances, including electrostatic discharges.

AA.2 Electromagnetic compatibility test levels

The ports which can be influenced by electromagnetic phenomena are:

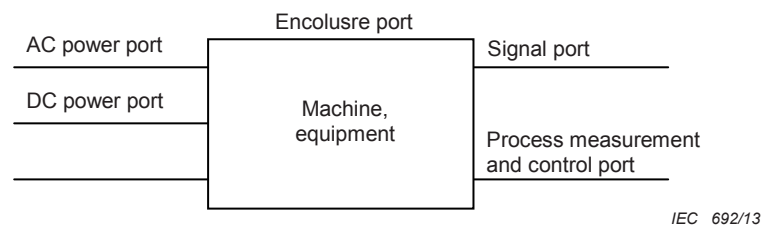

Figure AA.1 – Ports

The limits of electromagnetic compatibility specified in Tables AA.1 to AA.4 are effective:

- in the case of emission limits, for foreseeable use in a residential environment; and
- in the case of immunity, for use in the industrial environment characteristic of the sewing industry;

and therefore covers foreseeable use in all environments of the sewing industry.

AA.3 Emission

The electrical disturbances generated by the machine or by the equipment shall not exceed the levels specified in Table AA.1.

Measurement of interference voltages is not required on shielded lines which connect shielded parts of equipment. The shields shall be connected together.

Measurement of the interference voltages is not required on lines connecting parts of equipment which are less than 2 m in length and which cannot be extended.

AA.4 Immunity

Where electronic equipment is used, it shall be designed to withstand at least the test values specified in Tables AA.2 to AA.4.

The immunity test requirements for machines and equipment covered by this part of IEC 60204 are on a port to port basis.

AA.5 Performance criteria

Machines and equipment shall not become hazardous as a result of the application of the tests defined in this part of IEC 60204.

A functional description and a definition of performance criteria, during or as a consequence of the EMC testing, shall be noted in the test report, based on the following:

- **performance criterion A:** the machines and equipment shall continue to operate in the intended manner. No degradation of performance or loss of function is allowed below a performance level specified by the manufacturer, when the machines and equipment are used as intended. In some cases, the performance level may be replaced by a permissible loss of performance;
- **performance criterion B:** the machines and equipment shall continue to operate in the intended manner after the test. No degradation of performance or loss of function is allowed below a performance level specified by the manufacturer, when the machines and equipment are used as intended. In some cases, the performance level may be replaced by a permissible loss of performance. During the test, degradation of performance is however allowed. No change of actual operating state or stored data is allowed.
- **performance criterion C:** a temporary malfunction is permissible, if the function is self-recovering or recoverable by activation of the operating and/or setting elements.

If either the minimum performance level or the permissible performance loss is not specified by the supplier, then either of these may be derived from the product description and documentation and what the user may reasonably expect from the machines and equipment when used in the intended manner.

AA.6 Electromagnetic compatibility tests

AA.6.1 General electromagnetic compatibility (EMC) test conditions

The EMC tests shall be carried out:

- within the specified operating conditions for sewing units and systems or equipment and its nominal supply voltage;
- on completely equipped and ready-for-use sewing units and systems or, for sewing systems, on the individual machines in working order which build the entirety of the system;
- on sewing units and systems or equipment arranged in their maximum extension (for example controls with the maximum number of inputs/outputs and functions, all machines and equipment with minor configurations being considered to be in accordance with this part of IEC 60204);
- as single tests in sequence, the sequence of the test being optional.

The configuration and mode of operation during the test shall be precisely noted in the test report.

It is not always possible to test every function of the machine, and in such cases the most critical mode of operation shall be selected.

It may be determined, from consideration of the electrical characteristics and usage of particular machines and equipment, that some of the tests are inappropriate and are therefore unnecessary. In such a case, the decision not to test shall be recorded in the test report.

The sewing machine drive and additional equipment shall be tested on a standard sewing unit equipped as shown in Figure AA.1.

The sewing machine drives and equipment thus tested will be regarded as EMC-prepared. Specific test measures shall be agreed upon with the suppliers involved.

NOTE EMC-prepared equipment cannot guarantee solely the EMC-compatibility of the sewing unit or sewing system.

Measurements shall be performed under well-defined and reproducible conditions for each type of EMC phenomenon.

AA.6.2 EMC test conditions for emission

The description of the test and the test equipment shall be as given in Clauses 7 and 8 of CISPR 11:2009, Amendment 1:2010.

The test shall be carried out using the test set-up shown in Figure AA.2, except that the requirements for the ground plane shall be according to Clause 8 of CISPR 11:2009, Amendment 1:2010.

AA.6.3 EMC test conditions for immunity

The description of the test, the test methods and test equipment are given in the standards listed in Tables AA.2 to AA.4.

The test shall be carried out using the test set-up shown in Figure AA.2.

The test for sewing systems may differ from this test set-up.

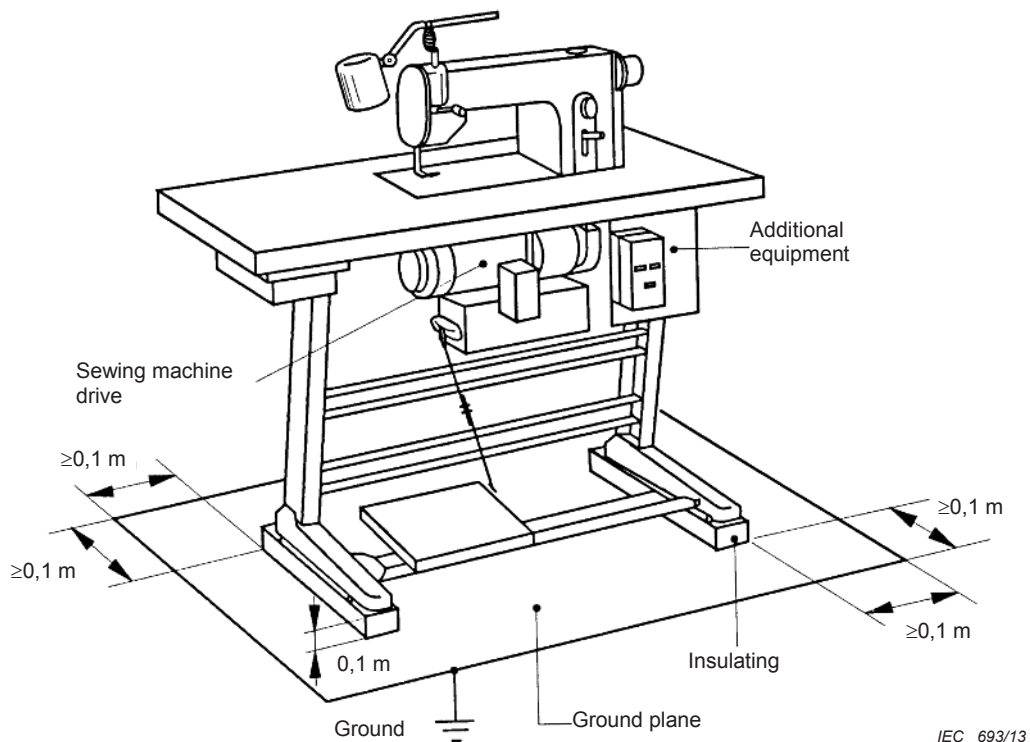

IEC 693/13

Figure AA.2 – Standard sewing unit for EMC tests

http://www.china-gadgets.com/

Table AA.1 – Emission – Radiated (enclosure) and conducted (AC mains)

Port	Frequency range	Limits	Basic standard	Applicability Note	
Enclosure	30 MHz – 230 MHz	30 dB(μ V/m) quasi-peak, measured at a 10 m distance	CISPR 11	See Note 1	
	230 MHz – 1 000 MHz	37 dB(μ V/m) quasi-peak, measured at 10 m distance			
AC mains	150 kHz – 0,5 MHz	66 dB(μ V) quasi-peak			See Notes 2, 3 and 4
		56 dB(μ V) average decreasing linearly with the logarithm of the frequency			
	0,5 MHz – 5 MHz	56 dB(μ V) quasi-peak			
	5 MHz – 30 MHz	46 dB(μ V) average 60 dB(μ V) quasi-peak 50 dB(μ V) average			

NOTE 1 In situ measurements are excluded from this standard.

NOTE 2 Impulse noise (clicks) which occurs less than five times per minute is not considered. For clicks appearing more often than 30 times per minute, the limits of Table AA.1 apply. For clicks appearing between five and 30 times per minute, a relaxation of 20 log 30/N dB of the limits of Table AA.1 is allowed (where N is the number of clicks per minute).

NOTE 3 Applies only to machine and equipment operating at less than 1 000 V RMS (Root Mean Square).

NOTE 4 These values are part of CISPR 11.

The requirements of IEC 61000-3-2 and IEC 61000-3-3 shall apply.

Table AA.2 – Immunity – Enclosure protection

	Environmental phenomena	Test specification	Units	IEC standard	Remarks	Performance criteria
1.1	Magnetic field at power frequency	50, 60 30	A/m	IEC 61000-4-8	The test is to be executed according to the power supply frequency. Equipment (company equipment, devices) that is intended to be used in regions that are only supplied by one of these frequencies have to be tested at this frequency only ^a .	A ^b
1.2	electromagnetic HF-field, amplitude modulated	80 – 1 000 10 80	MHz V/m % AM (1 kHz)	IEC 61000-4-3	The specified test level is the RMS prior to modulation ^c	A
1.3	electromagnetic HF-field, amplitude modulated	1.4 to 2.0 3 80	GHz V/m % AM (1 kHz)	IEC 61000-4-3	The specified test level is the RMS prior to modulation ^d	A
1.4	electromagnetic HF-field, amplitude modulated	1.4 to 2.7 1 80	GHz V/m % AM (1 kHz)	IEC 61000-4-3	The specified test level is the RMS prior to modulation ^d	A
1.5	Discharging static electricity	±4 (charge voltage)	kV	IEC 61000-4-2	See basic standard for applicability of contact and/or air discharge test	B
	Contact discharge	±8 (charge voltage)	kV			B

^a Only for company equipment (devices) which contain devices (components) that are sensitive to magnetic fields.

^b For monitors with cathode ray tubes the acceptable jitter depends on the font size and is calculated for a test level of 1 A/m according to: $J \leq (3C + 1)/40$. The jitter J and the font size C is in mm. As the jitter is linearly proportional to the magnetic field strength, tests may be carried out with other test levels, whereas the maximum jitter has to be extrapolated.

^c Except for the ITU broadcast frequency bands: 87 MHz – 108 MHz, 174 MHz – 230 MHz and 470 MHz – 790 MHz, where the level is 3 V/m.

^d The frequency ranges have been selected so that frequencies with the highest interference potential are detected.

Table AA.3 – Immunity – Ports for signal lines and data buses

Environmental phenomena	Test specification	Units	Basic standard	Test set-up	Remarks	Performance criteria
Radio-frequency common mode. Amplitude modulated	0,15 – 80 10 80 150	MHz V (RMS, unmodulated) % AM (1 kHz) Source impedance (Ω)	IEC 61000-4-6	IEC 61000-4-6	See Notes 1, 2 and 3. The test level specified is prior to modulation.	A
Fast transients	1 5/50 5	kV (peak) Tr/Tf (µs) Repetition frequency kHz	IEC 61000-4-4	IEC 61000-4-4 (capacitive clamp)	See Note 3	B
NOTE 1 The test level can be defined as the equivalent current into a 150 Ω load.						
NOTE 2 Except for the ITU broadcast frequency band: 47 MHz – 68 MHz, where the level is 3 V.						
NOTE 3 Applicable only to ports interfacing with cables whose total length according to the manufacturer's functional specification exceeds 3 m.						

The requirements of IEC 61000-4-5 shall not apply as the cable length is much lower than 30 m. See IEC 61000-6-2:2005 Table 2 Footnote d.

Table AA.4 – Immunity – AC input and AC output ports

	Environmental phenomena	Test specification	Units	Basic standard	Remarks	Performance criteria
4.1	Radio-frequency asymmetric	0,15 – 80 10 80	MHz V % AM (1 kHz)	IEC 61000-4-6	The test level specified is the RMS value prior to modulation. ^{ab}	A
4.2	Voltage dips	0 1	% residual voltage cycles	IEC 61000-4-11	Voltage jump during zero passage ^c	B ^d
		40 10/12 at 50/60 Hz	% residual voltage cycles			
4.3	Voltage interruptions	0 250/300 at 50/60 Hz	% residual voltage cycles	IEC 61000-4-11	Voltage jump during zero passage ^c	C ^d
4.4	Surge voltages asymmetrically (conductor / earth) symmetrically (conductor / conductor)	1.2/50 (8/20) ± 2 ± 1	T _r /T _h μs kV (open-circuit voltage) kV (open-circuit voltage)	IEC 61000-4-5	See Clause 5, 3 rd paragraph of IEC 61000-4-5:2005	B
4.5	Fast transients	± 2 5/50 5	kV (charge voltage) T _r /T _h ns Repetition frequency kHz	IEC 61000-4-4		B

a The test level can be defined as the equivalent current into a 150 Ω load.
b Except for the ITU broadcast frequency band: 47 MHz – 68 MHz, where the level is 3 V.
c Only for inputs.
d For electronic power converter, the respond of the protective device is allowed.

Bibliography

IEC 60335-2-28, *Household and similar electrical appliances – Safety – Part 2-28: Particular requirements for sewing machines*

IEC 61000-6-2:2005, *Electromagnetic compatibility (EMC) – Part 6-2: General standards – Immunity for industrial environments*

ISO 4915:1991, *Textiles – Stitch types – Classification and terminology*

ISO 4916:1991, *Textiles – Seam types – Classification and terminology*

<http://www.china-gauges.com/>

<http://www.china-gauges.com/>

<http://www.china-gauges.com/>

British Standards Institution (BSI)

BSI is the national body responsible for preparing British Standards and other standards-related publications, information and services.

BSI is incorporated by Royal Charter. British Standards and other standardization products are published by BSI Standards Limited.

About us

We bring together business, industry, government, consumers, innovators and others to shape their combined experience and expertise into standards-based solutions.

The knowledge embodied in our standards has been carefully assembled in a dependable format and refined through our open consultation process. Organizations of all sizes and across all sectors choose standards to help them achieve their goals.

Information on standards

We can provide you with the knowledge that your organization needs to succeed. Find out more about British Standards by visiting our website at bsigroup.com/standards or contacting our Customer Services team or Knowledge Centre.

Buying standards

You can buy and download PDF versions of BSI publications, including British and adopted European and international standards, through our website at bsigroup.com/shop, where hard copies can also be purchased.

If you need international and foreign standards from other Standards Development Organizations, hard copies can be ordered from our Customer Services team.

Subscriptions

Our range of subscription services are designed to make using standards easier for you. For further information on our subscription products go to bsigroup.com/subscriptions.

With **British Standards Online (BSOL)** you'll have instant access to over 55,000 British and adopted European and international standards from your desktop. It's available 24/7 and is refreshed daily so you'll always be up to date.

You can keep in touch with standards developments and receive substantial discounts on the purchase price of standards, both in single copy and subscription format, by becoming a **BSI Subscribing Member**.

PLUS is an updating service exclusive to BSI Subscribing Members. You will automatically receive the latest hard copy of your standards when they're revised or replaced.

To find out more about becoming a BSI Subscribing Member and the benefits of membership, please visit bsigroup.com/shop.

With a **Multi-User Network Licence (MUNL)** you are able to host standards publications on your intranet. Licences can cover as few or as many users as you wish. With updates supplied as soon as they're available, you can be sure your documentation is current. For further information, email bsmusales@bsigroup.com.

BSI Group Headquarters

389 Chiswick High Road London W4 4AL UK

Revisions

Our British Standards and other publications are updated by amendment or revision.

We continually improve the quality of our products and services to benefit your business. If you find an inaccuracy or ambiguity within a British Standard or other BSI publication please inform the Knowledge Centre.

Copyright

All the data, software and documentation set out in all British Standards and other BSI publications are the property of and copyrighted by BSI, or some person or entity that owns copyright in the information used (such as the international standardization bodies) and has formally licensed such information to BSI for commercial publication and use. Except as permitted under the Copyright, Designs and Patents Act 1988 no extract may be reproduced, stored in a retrieval system or transmitted in any form or by any means – electronic, photocopying, recording or otherwise – without prior written permission from BSI. Details and advice can be obtained from the Copyright & Licensing Department.

Useful Contacts:

Customer Services

Tel: +44 845 086 9001

Email (orders): orders@bsigroup.com

Email (enquiries): cservices@bsigroup.com

Subscriptions

Tel: +44 845 086 9001

Email: subscriptions@bsigroup.com

Knowledge Centre

Tel: +44 20 8996 7004

Email: knowledgecentre@bsigroup.com

Copyright & Licensing

Tel: +44 20 8996 7070

Email: copyright@bsigroup.com